



VEDA FRANCE

Joints bâtiment - Building joints

Joint de dilatation de sol

Mechanical floor joint

Série JDH 5.10

Joint de dilatation de sol pour extérieur et intérieur constitué de cornières en laiton et d'un insert souple interchangeable de couleur noir, gris ou beige pour tout type de finition : dalle, chape, carrelage, marbre, etc.

Mechanical floor expansion joint made of brass side plates and interchangeable black, grey or beige flexible insert for all types of finishes : screed, natural stone, cast stone, marble, etc.

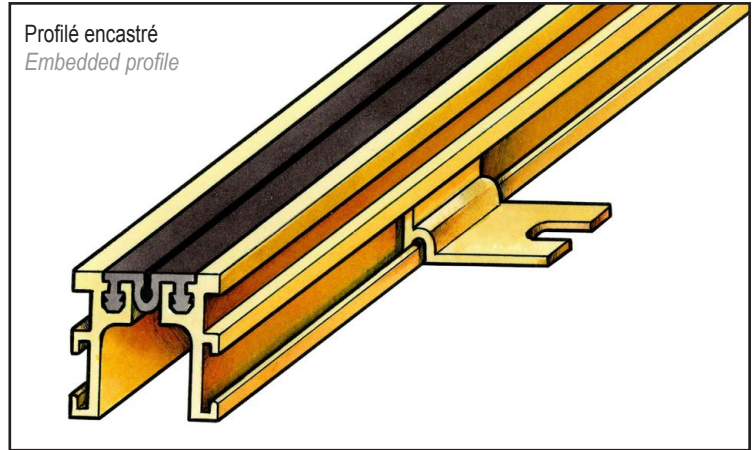

JDH 5.10

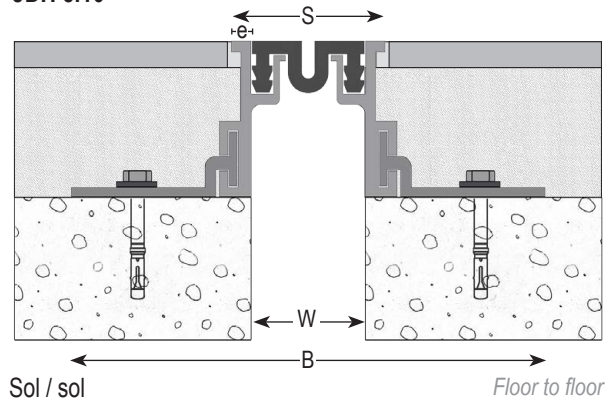

Réf. JDH 5.10	5.10-030
W [mm] ouverture / Gap up to [mm]	30
H [mm] hauteur / Depth [mm]	40
B [mm] approx.	115
S [mm] approx.	40
e [mm] approx.	5
Mouvement admissible M [mm] Accomodation of movement M [mm]	+10 / -5
Couleur / Color	Noir, gris / Black, grey
Matériau / Material	Laiton / Brass
Longueur standard [ml] / Standard length [lm]	3
Equerres de fixation [par mètre] / Number of fixings [per meter]	4
Charge [kN] / Load-bearing capacity [kN]	

© Tous droits réservés - Dessins non contractuels - 03/2014



GV2 - VEDA FRANCE
20, Allée des Erables - 93420 Villepinte - France
Adresse Postale
CS 63052 - 95972 Roissy CDG Cedex

Tél : + 33 (0)1 48 61 70 80
Fax : + 33 (0)1 48 61 70 81
E-mail : contact@vedafrance.com
Web : www.vedafrance.com